

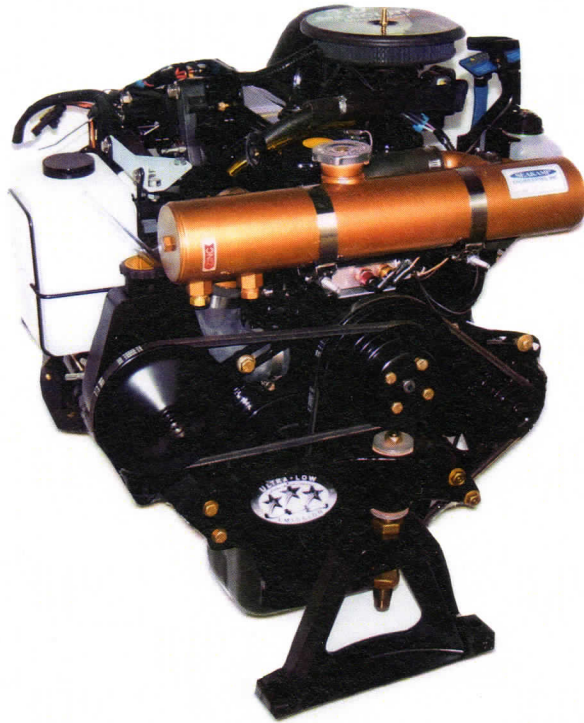

FRESHWATER COOLING KITS

FOR MERCUISER 3.0 L ENGINES



**ENGINE BLOCK
COOLING
PART NO. SK4810**

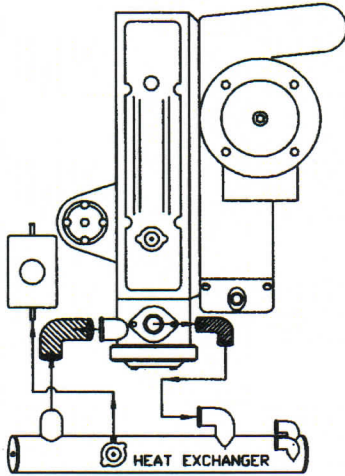

COOLANT FLOW SCHEMATIC

Extend the life of your engine while protecting it from corrosion with this EASY TO INSTALL, quality built, and uniquely designed heat exchanger cooling system.

1. Get improved fuel efficiency through more uniform engine operating temperatures
2. Adapts to use of cabin heater in cooler climates
3. Simplifies winterizing
4. Zinc anode helps control electrolysis
5. Kit includes detailed installation instructions
6. Benefit of inhibiting rust antifreeze protection
7. Workmanship and materials are fully guaranteed

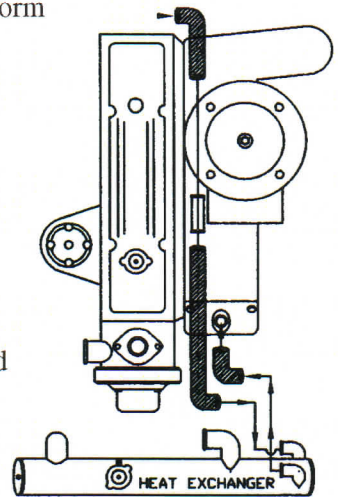

SEAWATER FLOW SCHEMATIC

Modern manufacturing techniques have evolved into a less expensive assembly process, while maintaining quality. These savings are passed on to you.

This is a complete kit, there is nothing extra to buy.

